

Williamsburg Spinners & Weavers Guild

P.O. Box 2086
Williamsburg, VA 23187
<http://Williamsburgspinweave.org>

January 2011

January Meeting

Monday 1/17/11

10:00 am (9:30 a.m. social time) to 1:00 p.m.
Room C, James City County Recreation Center
5301 Longhill Road, Williamsburg

Program

Rosalie Brown & Judy Mooers will do a program on triaxial weaving.

Refreshments

Savory - Virginia Banks
Sweet - Marsha Rehkamp

Bash

There will be no bash in January.

Happy
New
Year

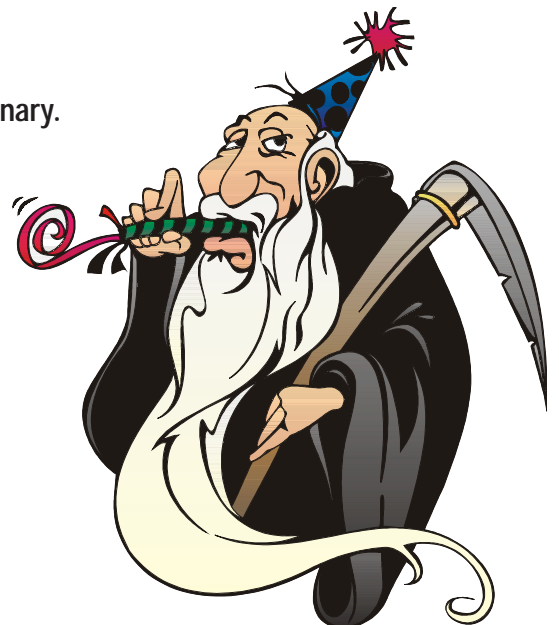

Minutes 12/20/10

President Rosalie Brown called the meeting to order at 10:00 am. She welcomed two guests: Thea Nelson (Ingrid Kross's mother) and Bob Marquez (Bernadette's husband).

Minutes for the November meeting were approved as written in the December newsletter.

Treasurer: Ingrid Kross reports \$3680.34 in the checking account. Annual dues for 2011 (\$20) are due at the December meeting. Handwoven and Spin-off magazines have been renewed for 2 years. Ingrid is still waiting for details on subscribing to Wild Fiber. She will also look into the status of Weavers Craft magazine.

Librarian: Mary Lou Birns was not in attendance. Marsha Rehkamp (magazines) will compile a list of missing Weavers Craft issues to be replaced.

Newsletter: Barbara Frey has looked through the old notebooks of other Guild newsletters. She will save only the weaving draft pages. She has been in touch with the Richmond Weaver's Guild; we will begin exchanging newsletters again.

Historian: Bernadette Marquez has nothing to report. Rosalie is going to get together with Pam Frank to look through, identify and consolidate the older photo albums.

Programming: Sandi was not at the meeting, but she emailed a list of upcoming programming information, which follows:

January: Rosalie Brown & Judy Mooers will do a program on triaxial weaving.

February meeting - we are all going to take the weaving survey - Judy would you please get a copy of the survey for us? We will start with some of our book reports.

March: We will share and discuss the survey results and everyone is to bring a source of inspiration to share and we will all work together to problem solve and find "just the right" use for that yarn or fleece you just "had" to have!! More book reports.

April: Michael Cook

May: I think another spin in day.

Snacks : Sign-up sheet was sent around for 2011 snacks.

Jan: Virginia, sweet; Marsha savory
February: Cathy Sterling sweet; Ingrid savory
March: Barbara sweet; Claudia savory
April: Bernadette sweet; Judy savory
May: Linda sweet; Mary Lou savory
July: Ingrid sweet; ? savory

Bash: Sign-up sheet was sent around for 2011 bashes. Very few sign-ups!

January: No bash

February: ?

March: ?

April: Judy

May: Ingrid

June: ?

July: ?

Old Business: The Nominating Committee presented the following proposed slate of officers for 2011:

President: Beth Palmer

Vice President: Sandi Petty

Treasurer: Ingrid Kross

Secretary: Marsha Rehkamp

Judy Mooers made the motion to accept the nominated slate of officers; Bernadette Marquez seconded. The slate passed unanimously.

New Business: The Fiber Festival (i.e.- "the quilt show") will take place the last weekend in February. The Guild will present a "Sheep to Shawl" demonstration. Set-up will take place Wednesday; the booth needs to be "baby-sat" on Thursday; the demos will take place Friday & Saturday; and everything needs to be disassembled and removed at the end of the day on Saturday. Ingrid will pass around the sign-up sheet at the January meeting. Ingrid will check the stock of Guild brochures and business cards. Barbara Frey will make more up as needed.

The Bay School Fiber Arts Show will be January 21-February 12, 2011. Entries are due by January 18 (\$25 entry fee for up to three pieces). Contact Barbara Frey for more information.

MAFA conference will be held in July in Gettysburg, PA. The course listing and applications are available on-line.

Rosalie has a Nigerian milking goat and a new angora rabbit at the farm.

(continued from page 2)

Show & Tell:

Barbara Frey: red socks and a "feather & fan" design shawl (in progress) with her own hand-spun wool.

Claudia Melgaard: a nylon knitted cowl (in progress)

Bernadette Marquez: fiber from Dolly Gauss's yarn, and a bag of sewing things to give away

Cathy Sterling: yarns from a knitting store: she needs advice on how to weave with them

Marsha Rehkamp: doubleweave pick-up ginko design and a weaving-too-fast and not-listening-to-the-rhythm-of-the-structure mistake.

Judy Mooers: woven checkerboard and checkers bag; SOAR workshop notebook.

Rosalie: cotton chenille towels (& a weaving-too-fast mistake- no header for a hem on one towel).

Today's program: pot-luck luncheon and Christmas card exchange

Respectfully submitted,
Marsha Rehkamp
Secretary

Members in attendance:

Linda Adamchak, Rosalie Brown, Barbara Frey, Ingrid Kross, Bernadette Marquez, Claudia Melgaard, Judy Mooers, Selma Moore, Beth Palmer, Marsha Rehkamp, Frankie Snipes, Cathy Sterling, David & Virginia Banks

Book Reviews

Contact our librarian, Mary Lou Birns, to get one of the books from our library and write a short review. We will be presenting the reviews at both the February and March meetings.

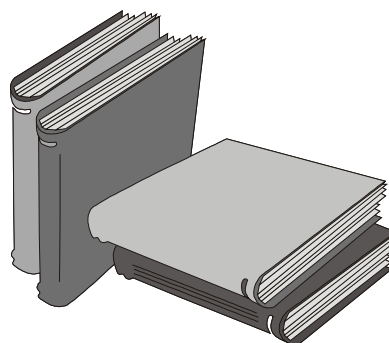

<http://www.handweaving.net/Home.aspx>

Weaving Draft Archive

This website contains 58467 hand weaving drafts, with more being added often. Each draft includes the standard threading, tieup, treadling, and color draw-down. Drafts can be viewed, printed, and downloaded in WIF format. You can easily share your own drafts with other weavers here using our draft contribution page.

Handweaving.net Store

We offer weaving books from Amazon.com as well as low cost CD-ROMs of many drafts and nearly all of the documents in the Griswold Archive on Weaving, Textiles, Lace, and Related Topics. Our CDs are easy to use and work with any type of computer. These purchases and donations help us to continue freely providing and expanding this site for you!

Griswold Digital Archive of Documents on Hand Weaving, Lace, and Related Topics

Ralph Griswold's Digital Archive of Documents on Hand Weaving, Lace, and Related Topics is now part of this site! This is a fascinating and useful library of more than 8000 high quality digital reproductions of original works including over 140,000 pages. Any of these works can be obtained with just a few clicks.

Weaving Gallery

Be sure to visit our online Weaving Gallery with pictures of items woven from drafts obtained here. We have received some photos of exceptional weaving and encourage you to browse through the gallery! We welcome gallery submissions from all Handweaving.net visitors, so please consider sending pictures of your work for the gallery to inspire others around the world.

Removing Rust from Reeds

by Shirley Wilson, Newsletter Editor, Richmond Weavers Guild,
Newsletter Volume 35, No. 6, February, 2005

If you need to clean rust from reeds that have been setting around for a while, try Naval Jelly Rust Dissolver, available at your local home improvement center. A \$5.00 can, a pair of plastic gloves, and an afternoon cleaned seven reeds (with a bit left over). Tough spots might need a second application. After

cleaning and allowing to dry, I sprayed the reeds with some clear acrylic finish. The final step was encasing the edges in duct tape.

This was much faster than the last ones we cleaned where Norm and I spent two days using fine steel wool on about the same number of reeds.

Websites of Interest

www.weavingworld.ca/weave.htm
Ruthe Stove's Weavers Resources web page:

www.christinelaffer.com/(Tapestry weaver Christine Laffer's web site that has links to other sites.)

<http://www.textilemuseum.org>
(The Textile Museum in Washington DC)

forum.swarthmore.edu/geometry/rugs (A site about symmetry and form using oriental rug motifs. Good information about repetition in design. Put together by curator at The Textile Museum.)

www.allfiberarts.com. The weaving and spinning pages of about.com are being restructured into this

new website. Do check it out. Looks better than previous version and has lots of good information for all levels.

www.halcyonyarn.com I am not advertising Halcyon Yarn but this is an excellent web site. Lots of information about yarn, books and videos - some which have been difficult to find. Many of you new weavers have wanted to know where to get yarn and this is an excellent source.

www.habutextiles.com Absolutely glorious web site. The sample packet (about 40 pages for \$10) is out of this world. Not sure just how to use many of the items but just a joy to see.

Officers

President
Vice President
Treasurer
Secretary

Beth Palmer
Sandi Petty
Ingrid Kross
Marsha Rehkamp

